

**SOLAR YELLOW FLASHING LIGHT Ø300mm**



The new generation of Solar Led Traffic Lights is now available by Diasimco.

Higher light intensity and exclusive optical lensing results to brilliant, better color uniformity, and longer viewing distance.

The type of led lens used distributes the light evenly, having larger viewing angle and long lifespan of more than 80.000 hours.

UV stabilized polycarbonate material of black color is used for a robust, solid case design, with multi-layer sealed for covering the required weatherproof demands.

**TECHNICAL CHARACTERISTICS & FEATURES**

- LED Yellow aspect of 91 Led units.
- Light Intensity  $\geq 400\text{cd}$ .
- Flashing frequency  $45\pm 5$  times/min.
- Wavelength of  $590 \pm 5\text{nm}$ .
- $30^\circ$  Left / Right viewing angle.
- 4 level automatic dimming operation.
- Operating temperature between  $-40^\circ$  to  $+80^\circ\text{C}$ .
- Ingress Protection IP55.
- Visual distance  $\geq 500$  meters.
- Operating voltage 12,8V.
- Solar panel 8W.
- Solar peak current 0,5A.
- Li-ion battery capacity 3000mAh.
- Continuous operating period during cloudy weather is about 6 days.

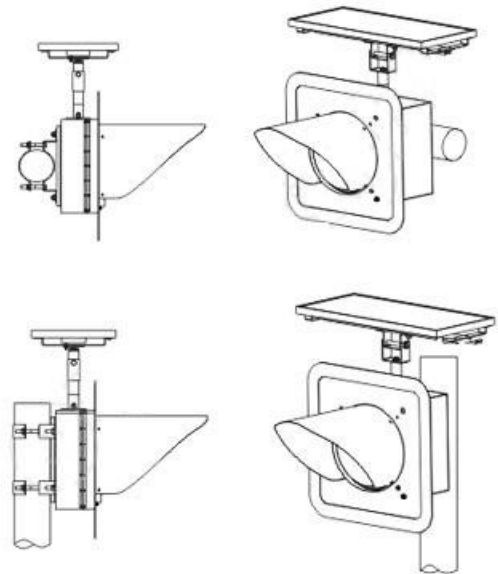

PACKING						
Model	Carton Size (m)	Quantity (pcs)	Net Weight (Kg)	Gross Weight (Kg)	Volume (m <sup>3</sup> )	
DC-FSS30	0,54 x 0.40 x 0.43	1	7	8,5	0,093	
PACKING LIST						
Item	Traffic Light with visor	Solar Panel 8W	M4x10 Screw	M12x80 Screw, Washer, Nut	M12x30 Screw, Washer, Nut	Bracket
Quantity	1	1	4	2	1	1

**DIASIMCO OE**

Address : 10, Acharnon Ave, Athens 10433, Greece, P.O Box : 8460 Omonia, Athens 10210, Greece  
Tel.:+30 210 5236404 Fax: +30 210 5231770, Web: www.diasimco.gr, www.trafficproducts.gr, www.trafficlights.gr